



June 22, 2026

To All Bidders:

Subject: **Bid No. 8721-M6 – Sewer Rehabilitation - Various Streets (S26-2) / DPW**

ADDENDUM NO. 2

To Whom It May Concern:

With reference to our bid request relative to the above subject, please refer to the changes/modifications/clarifications to the original proposal request.

Questions Received by this Office & Answers from the City:

- Q1. Per Massachusetts General Laws, Part I, Title III, Chapter 30, Section 39G, we respectfully request that the 10% withholding be removed from all bid items that include this provision, as it does not align with Massachusetts state law.
- A1. **The 10% withholding of payment on trenchless items represents incomplete work and is unrelated to retainage as allowed by M.G.L. c.30 §39G.**
- Q2. Can the owner confirm if the bid items for trenching and replacing 12” pipe is associated with the concrete pipe on Queen St (C-104)?
- A2. **Yes. It is anticipated that the 12-inch pipe on Queen Street may require open cut repairs prior to installation of CIPP.**
- Q3. Can the owner clarify how the bid item “connections” will be paid and what it covers? Bid item 224.
- A3. **Measurement and Payment of bid item 224 is provided in the City’s Department of Public Works Standard Construction Specifications and Details. See attachment SK1 for additional building connection details.**
- Q4. Can the Owner confirm that they understand that we can only grout service connections in round pipe?
- A4. **Prospective bidders shall provide supporting technical justification or documentation demonstrating that grouting of service connections is only feasible in round pipes.**

Bidders are requested to acknowledge and/or include this addendum with submission. All other terms, conditions and specifications remain unchanged.

Very truly yours,

Stephen R. McDonald
Assistant Purchasing Director

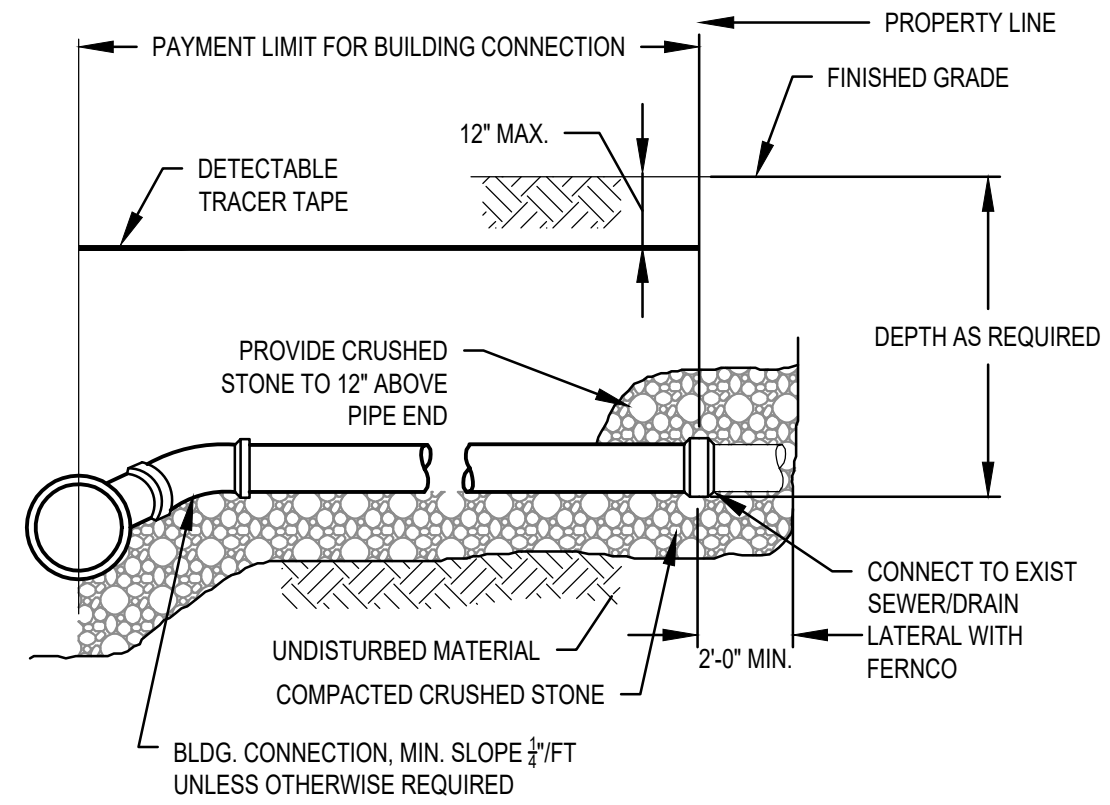
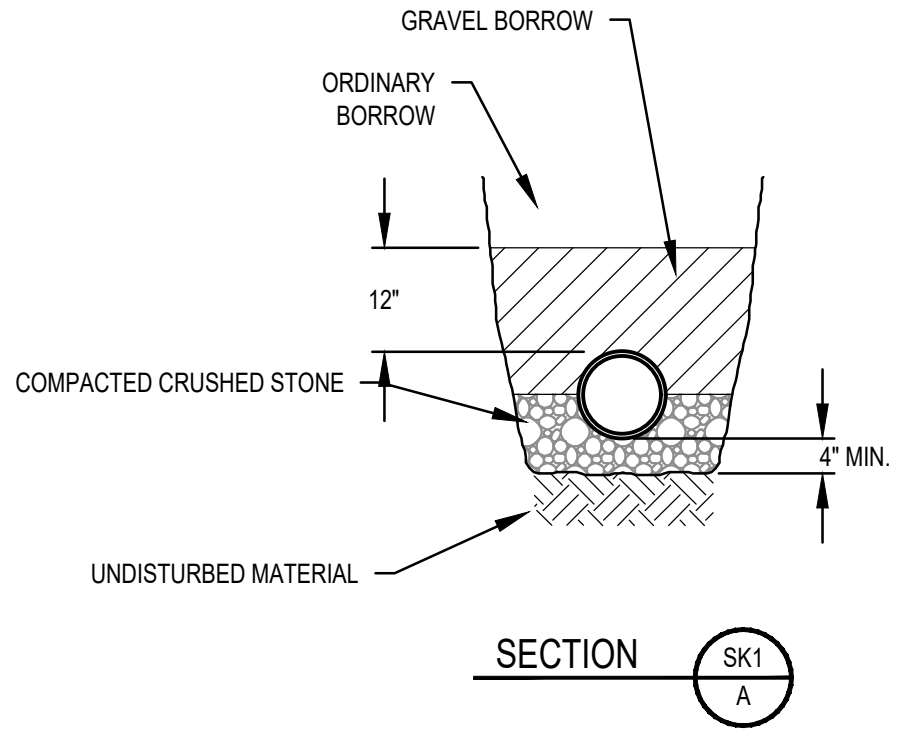
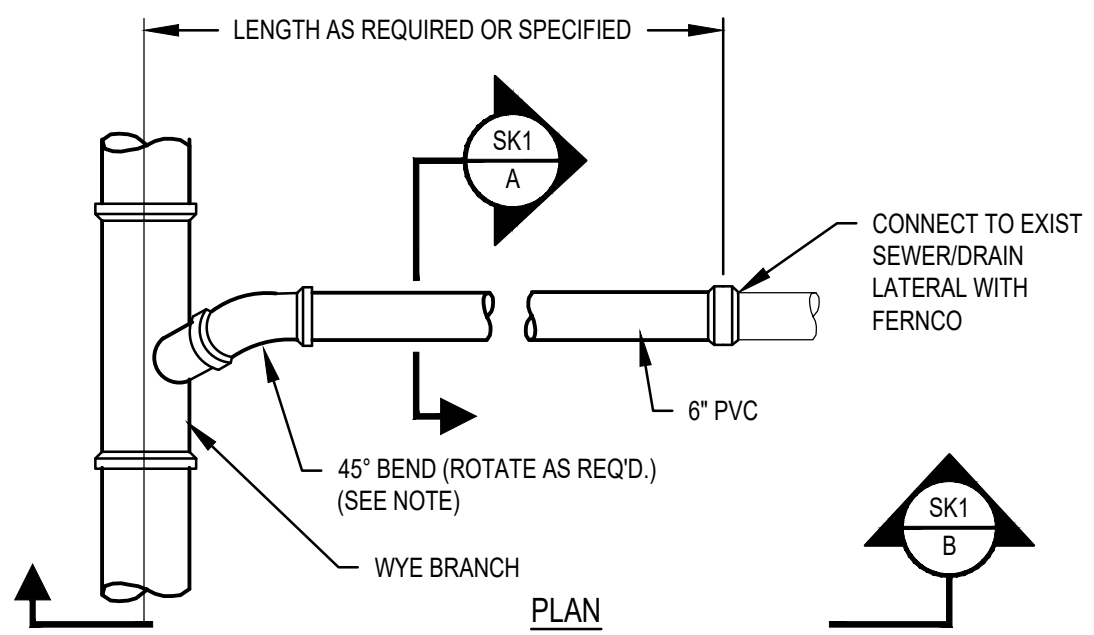

NOTE:
BE SURE THAT END OF BELL ON WYE BRANCH DOES NOT RUB ON UNDERSIDE OF 45° BEND.

SECTION SK1
B

TYPICAL BUILDING CONNECTION DETAIL
N.T.S

Project:
CITY OF WORCESTER,
MASSACHUSETTS
DEPARTMENT OF PUBLIC
WORKS

VARIOUS STREETS 2026
SEWER REHABILITATION
PROJECT

Weston & Sampson
Weston & Sampson Engineers, Inc.
427 Main Street, Suite 400
Worcester, MA 01608
978.532.1900 800.SAMPSON
www.westonandsampson.com

Revisions:

No.	Date	Description

Issued For:
RELEASED FOR
CONSTRUCTION

Scale: NO SCALE

Date: JUNE 2026
Drawn By: MHH
Reviewed By: KDK
Approved By: FEO

W&S Project No.: ENG25-0036
W&S File No.: SEE PATH

Drawing Title:
**BUILDING
CONNECTION DETAIL**

Sheet Number:
SK1

P:\MA\Worcester, MA\25-0036 Various Streets 2026 Rehab Design\06-BIM-CAD\01-Civil\Survey\Addendum 1 SK1.dwg